

SS3802

**RF & MICROWAVE DISCRETE
 LOW POWER TRANSISTORS**

Features

- Silicon NPN, To-39 packaged VHF/UHF Transistor
- Specified 400 MHz, 28Vdc Characteristics
 - Output Power = 1.0 Watt
 - Minimum Gain = 10 dB
 - Efficiency = 45%
- 800 MHz Current-Gain Bandwidth Product

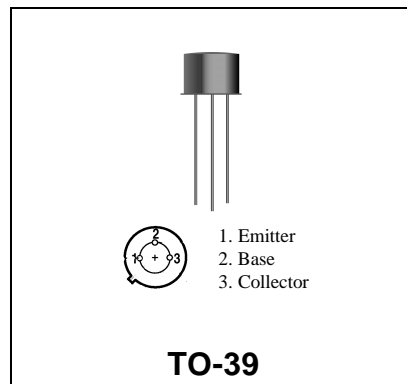

DESCRIPTION:

Silicon NPN transistor, designed for VHF and UHF equipment. Applications include amplifier; pre-driver, driver, and output stages. Also suitable for oscillator and frequency-multiplier functions.

ABSOLUTE MAXIMUM RATINGS (Tcase = 25°C)

Symbol	Parameter	Value	Unit
V _{CEO}	Collector-Emitter	30	Vdc
V _{CBO}	Collector-Base Voltage	55	Vdc
V _{EBO}	Emitter-Base Voltage	3.5	Vdc
I _c	Collector Current	400	mA

Thermal Data

P _D	Total Device Dissipation	5.0	Watts mW/ °C
	Derate above 25°C	28.6	

ELECTRICAL SPECIFICATIONS (Tcase = 25°C)

STATIC
 (off)

Symbol	Test Conditions	Value			Unit
		Min.	Typ.	Max.	
BVCER	Collector-Emitter Breakdown Voltage (IC = 5.0 mAdc, RBE = 10 ohms)	55	-	-	Vdc
BVCEO	Collector-Emitter Sustaining Voltage (IC=5.0 mAdc, IB=0)	30	-	-	Vdc
BVCBO	Collector-Base Breakdown Voltage (IE = 0, IC = 0.1 mAdc)	55	-	-	Vdc
BVEBO	Emitter-Base Breakdown Voltage (IE = 0.1 mAdc, IC = 0)	3.5	-	-	Vdc
ICEO	Collector Cutoff Current (VCE = 28 Vdc, IB = 0)	-	-	20	μA
ICEX	Collector Cutoff Current (VCE = 55 Vdc, VBE = 1.5 Vdc)	-	-	100	μA

(on)

HFE	DC Current Gain				
	(IC = 360 mAdc, VCE = 5.0 Vdc) Both	5.0	-	-	-
	(IC = 50 mAdc, VCE = 5.0 Vdc) 2N3866	10	-	200	-
	(IC = 50 mAdc, VCE = 5.0 Vdc) 2N3866A	25	-	200	-
VCE(sat)	Collector-Emitter Saturation Voltage (IC = 100 mAdc, IB = 20 mAdc)	-	-	1.0	Vdc

DYNAMIC

Symbol	Test Conditions	Value			Unit
		Min.	Typ.	Max.	
f _T	Current-Gain - Bandwidth Product (IC = 50 mAdc, VCE = 15 Vdc, f = 200 MHz)	500	800	-	MHz
	2N3866	800	-	-	
	2N3866A				
COB	Output Capacitance (VCB = 30 Vdc, IE = 0, f = 1.0 MHz)	-	2.8	3.5	pF

SS3802

FUNCTIONAL

Symbol	Test Conditions		Value			Unit
			Min.	Typ.	Max.	
G_{PE}	Power Gain	Test Circuit-Figure 1 Pin = 0.1 W, VCE = 28Vdc f = 400 MHz, TC = 25 C	10	-	-	dB
P_{out}	Output Power	Test Circuit-Figure 1 Pin = 0.1 W, VCE = 28Vdc f = 400 MHz, TC = 25 C	1.0	-	-	Watts
η_C	Collector Efficiency	Test Circuit-Figure 1 Pin = 0.1 W, VCE = 28Vdc f = 400 MHz, TC = 25 C	45	-	-	%

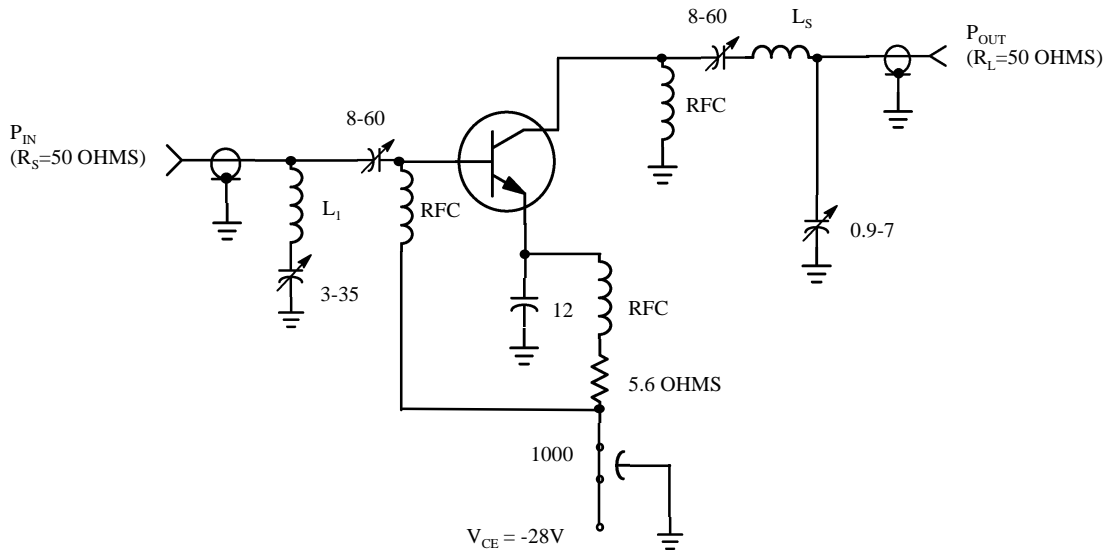

Figure 1 - 400 MHz RF AMPLIFIER CIRCUIT FOR G_{PE} , P_{OUT} , AND EFFICIENCY SPECIFICATIONS.

L_1 : 2 TURNS No. 18 wire, 1/4" ID, 1/8" long

L_S : 2 3/4 TURNS No. 18 wire, 1/4" ID, 3/16" long

Capacitor values in pF unless otherwise indicated.

Tuning capacitors are air variable

PACKAGE STYLE M246

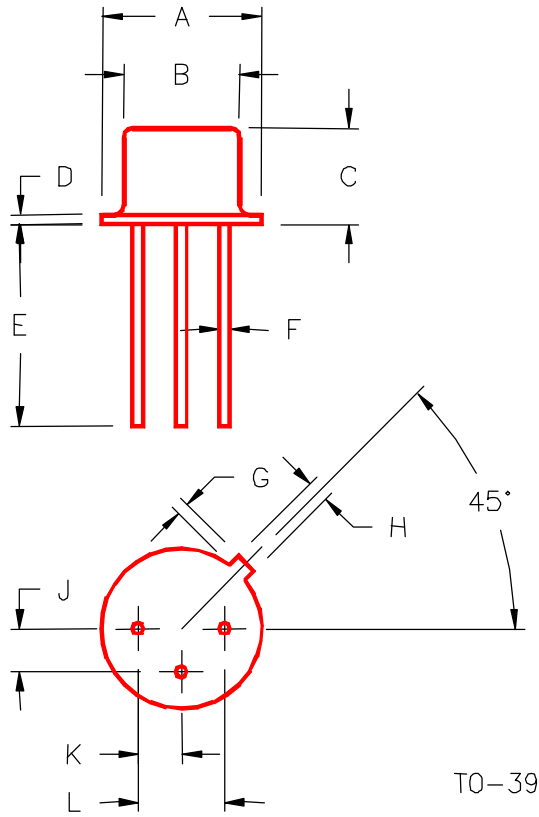

	MINIMUM INCHES/MM	MAXIMUM INCHES/MM		MINIMUM INCHES/MM	MAXIMUM INCHES/MM
A	.350/8,89	.370/9,40	J	.095/2,41	.105/2,67
B	.315/8,00	.335/8,51	K	.095/2,41	.105/2,67
C	.240/6,10	.260/6,60	L	.190/4,83	.210/5,33
D	.015/0,38	.045/1,14			
E	.500/12,70				
F	.016/0,41	.019/0,48			
G	.029/0,74	.040/1,02			
H	.028/0,71	.034/0,86			